

FICHES TECHNIQUES

# ROLF BENZ ELVA

---



**ROLF  
BENZ**

- Structure intérieure en bois
- Suspension à ressorts à boudin
- Assise en mousse moulée à froid de très grande qualité, couches superposées de hauteurs et densités différentes
- Dossier recouvert de mousse de polyuréthane
- Dossier recouvert de mousse froide dans sa partie supérieure
- Revêtement doublé de non-tissé polyester
- Hauteur d'assise au choix 42 cm ou 45 cm
- Pied en fonte d'aluminium, thermolaqué mat, deux teintes au choix :
  - RAL 9017 Noir trafic
  - RAL 7044 Gris soie

! Garnissage de grande qualité réalisé avec des matières particulièrement souples, ce qui entraîne l'apparition caractéristique d'ondulations / de marques d'assise après utilisation du siège. Toutes les dimensions indiquées sont approximatives.

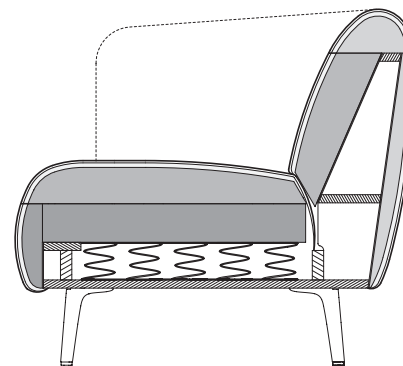

Hauteurs livrables

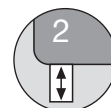

**ROLF  
BENZ**

Canapé

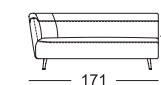
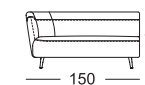
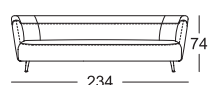
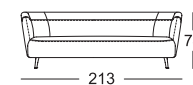
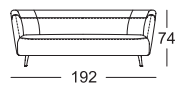
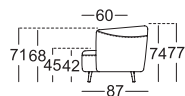
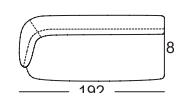
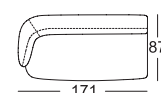
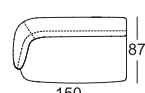
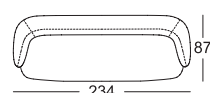
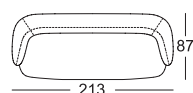
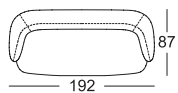

Canapé de fin d'angle\*

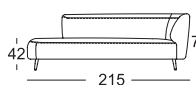
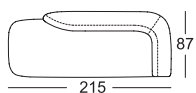

Canapé avec pouf fixé\*

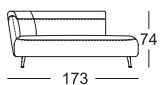
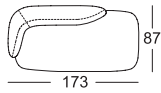

End chaise longue\*

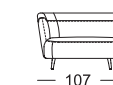
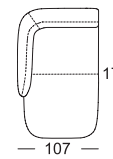
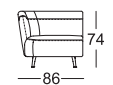
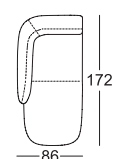

Pouf



Natte de coussins de dos



\*Ces éléments sont montrés sous une seule forme. Ils existent également en forme inversée.

**Exemples de composition:**

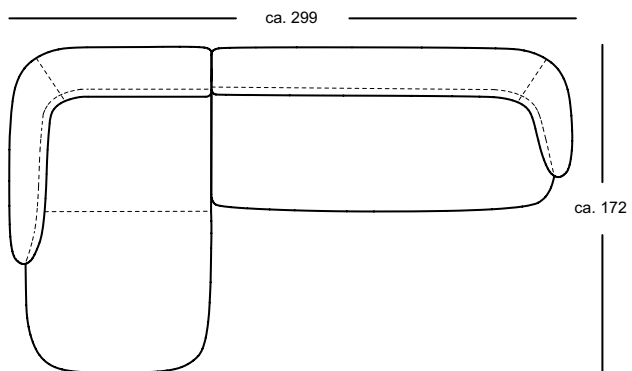

ALC 300/SB 84 à gauche  
ASO 300/SB 168 à droite

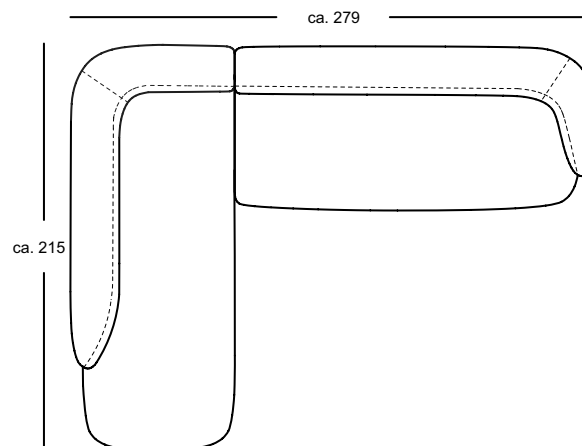

E-ASO-PSZ 300/SB 189 à gauche  
ASO 300/SB 168 à droite